

MEDICAL

GRIPPING SOLUTIONS
FOR THE MEDICAL
AND PHARMA
INDUSTRIES

2022



Customised components for the automation
of different laboratory applications.



MEDICAL & PHARMA

Tailor-made solutions for the medical sector

The medical sector requires massive automation in order to meet the ever-growing demands of the market. Speed, precision and reliability are key features in the medical industry.

For years, Gimatic has been supplying customised components to automate various applications in the laboratory. Standard products are modified to match customer needs, through technical changes to functions and adaptations of interfaces, speeds, forces and gripping fingers.



Main features:

1 Customised components to automate different applications in the laboratory.

2 Gimatic electric grippers can operate in production areas with a high level of cleanliness and hygiene.

3 Gimatic has created products that boast an ISO14644-1 Class 5 Cleanroom Certification and meet the requirements of the highest GMP (Good Manufacturing Practice) cleanliness classes of Grade A and B.

Why Gimatic Medical?

Usually plastic parts in medical and pharmaceutical applications are small and require extremely precise positioning, which means that EOATs (End of Arm Tooling) have to be very sophisticated and reliable to be up to their tasks. Gimatic offers a wide range of compact and lightweight products to achieve functional solutions.

Gimatic can meet the demand for customised, high-precision solutions for medical and pharmaceutical machines. High-speed machines require a secure grip and compact grippers.

Gimatic supplies standard and customised grippers for handling tubes and vials for inspection machines and laboratory automation, as well as many other grippers for medical machines.

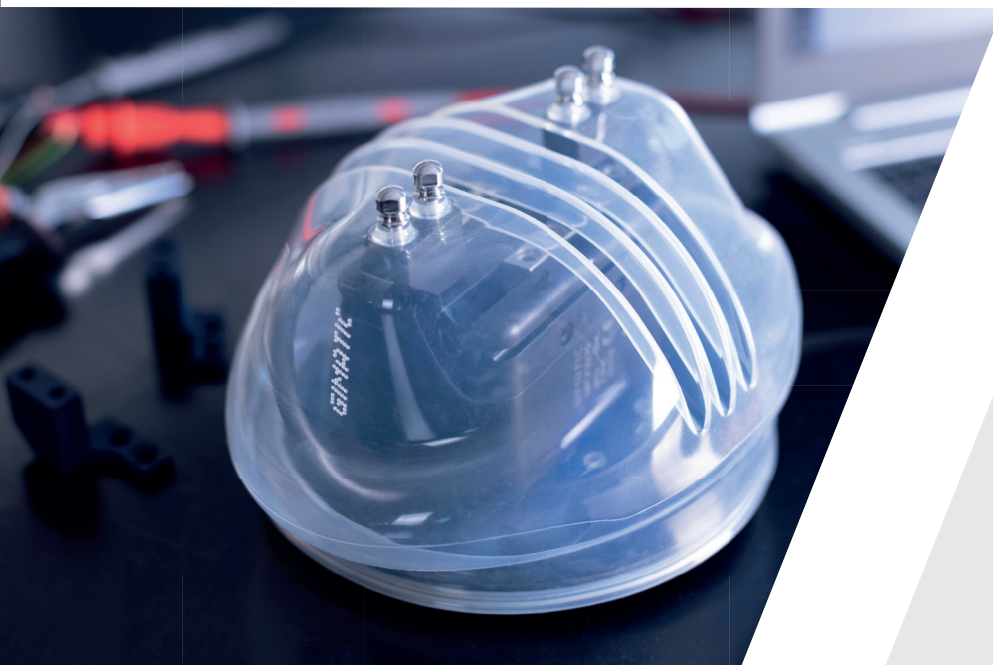

> Compact and lightweight products to achieve concrete solutions

> For cleanroom applications Gimatic has created special covers, easily sanitised, that can be added to all electric grippers.

Main Industries:



**PLASTICS INJECTION
MOULDING EOATs**



LAB AUTOMATION



**INSPECTION
MACHINES**



CLEANROOM



Some Success Stories

CLEANROOM GRIPPING SOLUTION

- > The Gimatic MPPM1606-GMP-KIT has been tested, together with the Denso Robot, by the IPA Fraunhofer Institute in Stuttgart.
- > Cover made in Wacker's Silpuran® silicone, compliant with FDA 21 CFR 177.2600* and FDA/EHEDG approved.
- > Compatible with hydrogen peroxide (VHP-H2O2) and UV cleaning procedures.



1 The GMP kit for Denso Robotics was created for the production of specific drugs for anti-cancer therapies. The solution is perfectly suited to cleanroom production facilities, i.e. environments with a low content of suspended particles. This is possible thanks to the high level of cleanliness (ISO 04) and the GMP level (Grade A / B).

The MPPM1606-KIT-GMP consists of the 2-jaws parallel linear self-centring electric gripper (MPPM1606), a silicone cover, special stainless steel fingers and ISO flange to be fixed directly on the robot.

Thanks to the transparent cover, the LEDs of the internal sensors are easy to read.

Accumulation of bacteria is prevented thanks to the smooth surface design, which is compatible with hydrogen peroxide (VHP-H2O2) and ultraviolet UV cleaning procedures.



Scan and watch the video!

EOAT TO HANDLE SOFT PE PART

2 Our 'Gimatic Nordic' Automation Center supplied a special EOAT to the Stockholm-based company Tiki Safety AB, which developed the Tiki mask.

Tiki is a full-face respiratory protection mask for use in harsh environments which has been used by healthcare workers against Covid-19. In the first months of the pandemic, demand for it increased rapidly and the company needed a very short delivery time.

'Gimatic Nordic' provided for free a customised EOAT capable of handling the soft PE part that seals the mask to the face.

- > Customised EOAT capable of handling the soft PE part.
- > The EOAT consisted of the **GS** self-centring parallel pneumatic grippers, the **SOQ** cubic photoelectric sensors and the **OFS** one-finger pneumatic gripper.

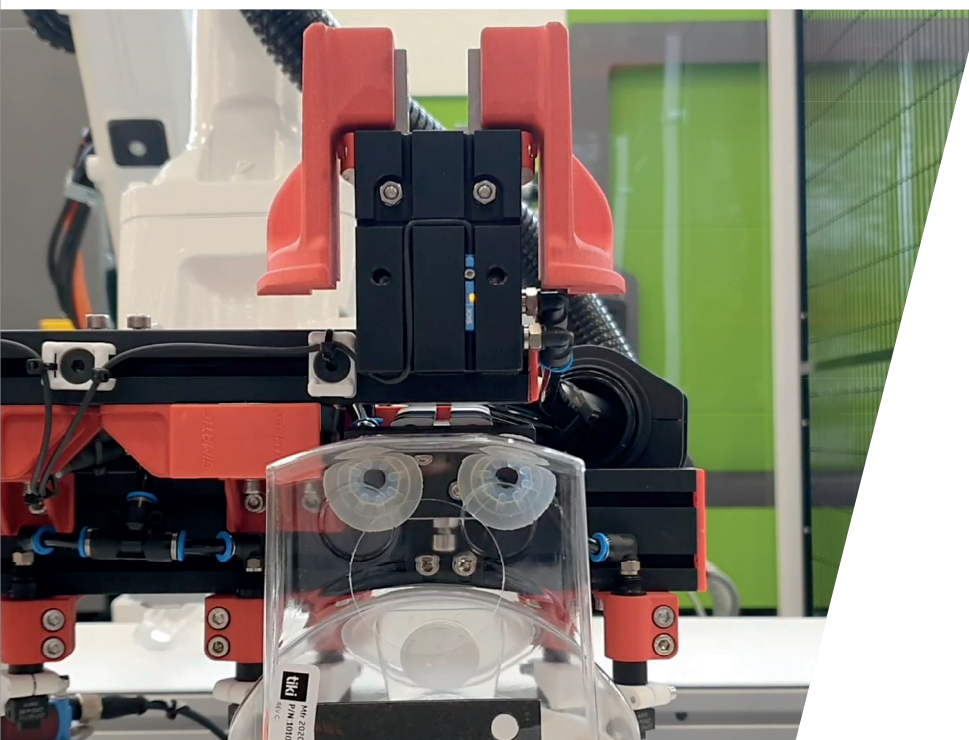

**Scan and watch
the video!**



MEDICAL & PHARMA

GMP Kit Gripping Solutions

- > Cover made in Wacker's Silpuran® silicone, compliant with FDA 21 CFR 177.2600* and FDA/EHEDG approved
- > Compatible with hydrogen peroxide (VHP-H2O2) and UV cleaning procedures.
- > Gimatic's GMP kits are certified by the IPA Fraunhofer Institute in Stuttgart.

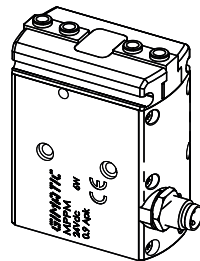
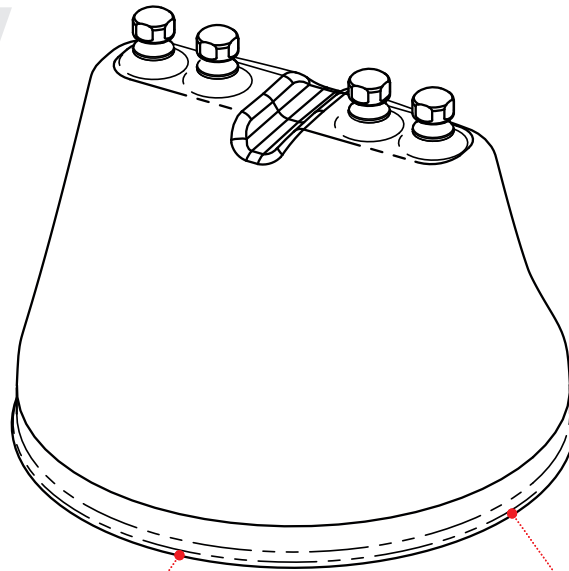

MPPM1606
MPPM2508
MPPM3210

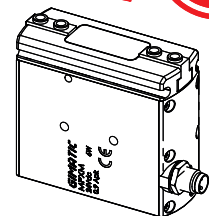

MPXM1612



Plug & Play

Gimatic's GMP Kit is compatible with the **MPPM/MPXM/MPLM** grippers. These grippers differ in stroke length and gripping force to meet the needs of different customers.

These grippers are **Plug & Play** and do not require any programming thanks to the control electronics integrated in the body. The smart control system creates a power interruption when the gripper has gripped the workpiece, thus saving energy.

The fingers of the grippers are easy to fix thanks to the anti-rotation system and can be used on both sides, therefore providing a grip from the inside to the outside and vice versa.

Servo Gripper

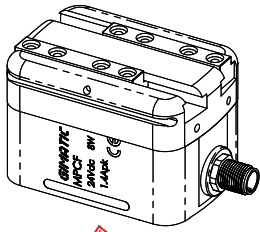

Coming soon
MPCF3270

Servo Gripper

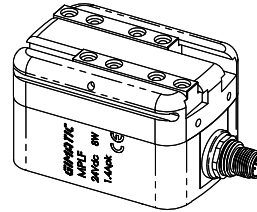

MPLF3270

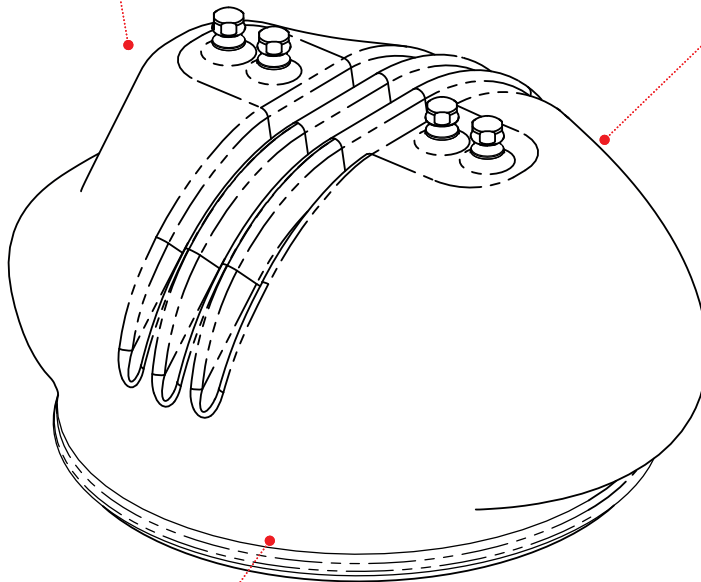

> In addition to the GPM kit, Gimatic has designed other Plug & Play components: the **MPTM1606** and **MRE16180** grippers and the **EQC20** tool changer.

> These products are certified for cleanroom applications by Fraunhofer.

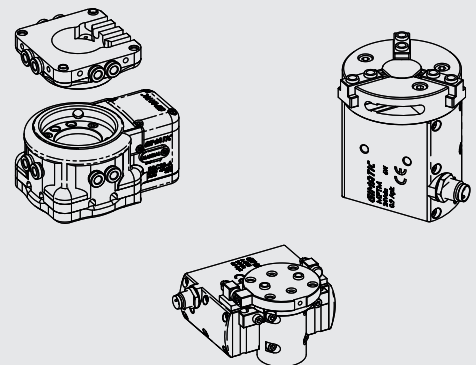

Plug & Play

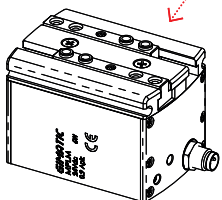

MPLM3240

Servo Gripper

Servo Grippers

The GMP kit can also be used with the **MPLF/MPCF** servo grippers. Using a drive, these new grippers enable to implement speed and force controls as well as any other customisable control algorithm.

The **MPLF** gripper enables the gripping system to be controlled by any commercially available drive compatible with the integrated type of motor and feedback device.

The **MPCF** gripper has an integrated drive that allows a quick installation on the collaborative robot.



Via Enzo Ferrari, 2/4
25030 Roncadelle (BS) ITALY

tel. +39 030 2584655
fax +39 030 2583886

info@gimatic.com
www.gimatic.com



Sales Network



* F L Y E R - M E D I C A L - E N *